

Standard Series FP634 6V3.4Ah

FirstPower®

Dimension

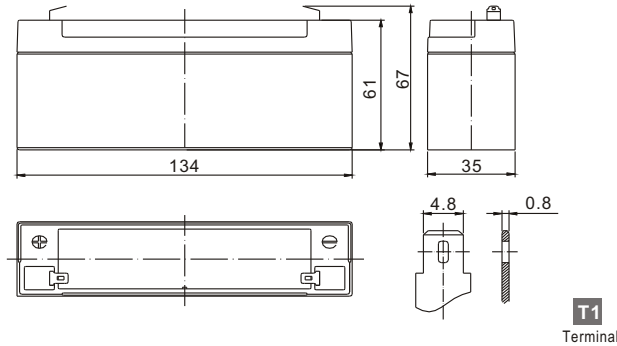

Specification

Nominal Voltage		6 V
Capacity(20HR, 25°C)		3.4Ah
Dimension	Length	134mm (5.28inch)
	Width	35mm (1.38inch)
	Height	61mm (2.40inch)
	Total Height	67mm (2.64inch)
Approx. Weight		0.71kg (1.57lbs)

Characteristics

Capacity 20°C (68°F) To 1.70V/Cell	20 hour rate	3.4Ah
	10 hour rate	3.0Ah
	5 hour rate	2.7Ah
	1 hour rate	2.0Ah
	15 min rate	1.46Ah
Internal resistance(Fully charged, 25°C)		Approx. 26mΩ
Capacity affected by temperature (20HR)	40°C	102%
	25°C	100%
	0°C	85%
	-15°C	65%
Self-discharge (25°C)	3 month	Remaining Capacity: 91%
	6 month	Remaining Capacity: 82%
	12 month	Remaining Capacity: 65%
Nominal operating temperature		25°C ±3°C(77°F ±5°F)
Operating temperature range		-15°C~50°C(5°F~122°F)
Float charging voltage(25°C)		6.80 to 6.90V
Cyclic charging voltage(25°C)		7.25 to 7.45V
Maximum charging current		1.02 A
Terminal material		Copper
Maximum discharge current		51A(5 secretary.)

The Relationship for Open Circuit Voltage and Residual Capacity (25°C)

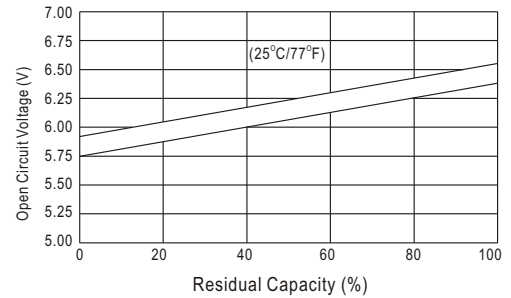

Charging Characteristics(25°C)

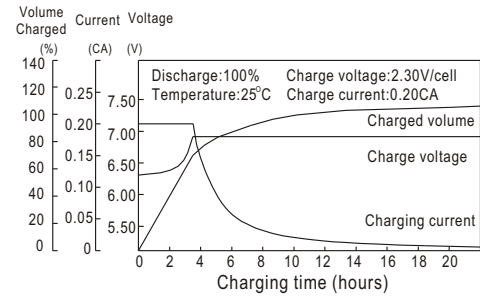

Cycle Life(25°C)

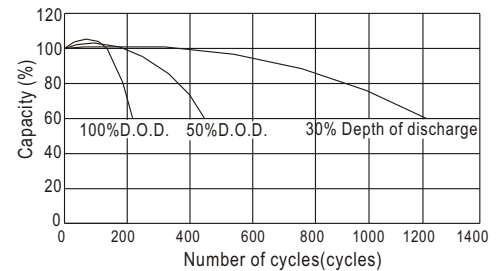

Constant Current Discharge Characteristics(A, 25°C)

F.V/TIME	5min	10min	15min	30min	60min	3h	5h	10h	20h
4.80V	12.9	8.16	6.46	3.74	2.21	0.86	0.59	0.32	0.17
5.10V	12.3	7.75	6.20	3.59	2.12	0.85	0.58	0.31	0.17
5.40V	11.5	7.29	5.89	3.41	2.02	0.83	0.57	0.31	0.17

Constant Power Discharge Characteristics(Watt, 25°C)

5min	10min	15min	30min	60min	3h	5h	10h	20h
72.1	46.0	36.8	21.4	12.8	5.12	3.50	1.90	1.04
68.5	43.7	35.3	20.6	12.3	5.05	3.45	1.89	1.03
64.4	41.1	33.6	19.5	11.7	4.95	3.38	1.89	1.02