

Standard Series FP434 4V3.4Ah

FirstPower®

Dimension(mm)

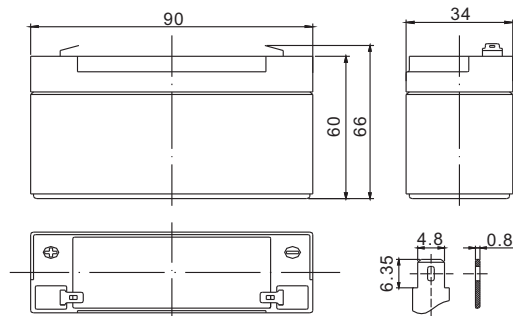

T1
Terminal



Specification

Nominal Voltage		4 V
Capacity(20HR, 25°C)		3.4Ah
Dimension	Length	90mm (3.67inch)
	Width	34mm (1.39inch)
	Height	60mm (2.45inch)
	Total Height	66mm (2.69inch)
Approx. Weight		0.46kg (1.01lbs)

Characteristics

Capacity 20°C (68□) To 1.70V/Cell	20 hour rate	3.4Ah
	10 hour rate	3.1Ah
	5 hour rate	2.9Ah
	1 hour rate	2.12Ah
	15 min rate	1.55Ah
Internal resistance(Fully charged, 25°C)		Approx. 20mΩ
Capacity affected by temperature (20HR)	40°C	102%
	25°C	100%
	0°C	85%
	-15°C	65%
Self-discharge (25°C)	3 month	Remaining Capacity: 91%
	6 month	Remaining Capacity: 82%
	12 month	Remaining Capacity: 65%
Nominal operating temperature		25°C ±3°C(77°F ±5°F)
Operating temperature range		-15°C~50°C(5°F~122°F)
Float charging voltage(25°C)		4.50 to 4.60V
Cyclic charging voltage(25°C)		4.85 to 4.95V
Maximum charging current		1.02A
Terminal material		Copper
Maximum discharge current		52A(5 Sec.)

The Relationship for Open Circuit Voltage and Residual Capacity (25°C)

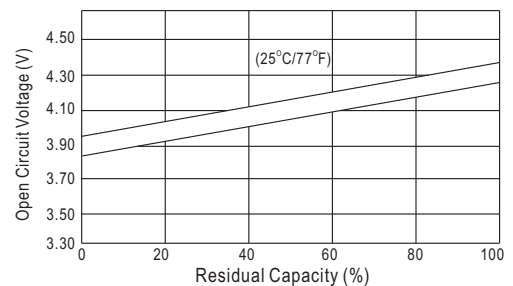

Charging Characteristics(25°C)

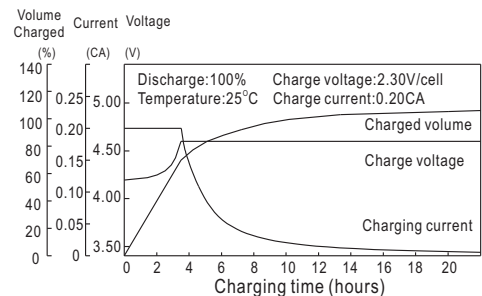

Cycle Life(25°C)

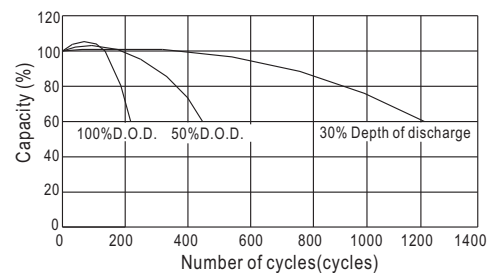

Constant Current Discharge Characteristics (A, 25°C)

F.V/TIME	5min	10min	15min	30min	60min	3h	5h	10h	20h
3.20V	12.9	8.16	6.46	3.74	2.21	0.86	0.59	0.32	0.17
3.40V	12.3	7.75	6.20	3.59	2.12	0.85	0.58	0.31	0.17
3.60V	11.5	7.29	5.89	3.41	2.02	0.83	0.57	0.31	0.17

Constant Power Discharge Characteristics (Watt, 25°C)

	5min	10min	15min	30min	60min	3h	5h	10h	20h
	48.1	30.7	24.5	14.3	8.53	3.42	2.33	1.27	0.69
	45.7	29.1	23.6	13.7	8.18	3.37	2.30	1.26	0.68
	42.9	27.4	22.4	13.0	7.80	3.30	2.25	1.26	0.68